

## General

The series 105 consist of a broad range of miniature valves and valves with various type of actuation. The connections are M5 for this series.

Due to their special construction with a balanced spool, these valves can be used interchangeably as 3 ways or 5 ways as can be seen in the functional schematics in section 0. This is important because, for example, the 3 ways can be used normally closed or normally open and the 5 ways can be fed through the exhausts 3 and 5 with different pressures according to the need. The spool, as it is moving, isolates the connections without being effected by the inlet pressure.

## Construction characteristics

	M5	G 1/8" - G 1/4" - G 1/2" - G 1"
Body	Nickel plated brass	Aluminium
Actuators	Nickel plated brass Stainless steel for roller levers and button levers. Zinc plated steel for side levers Plastic material for handles, buttons, switches	Aluminium
Seals	NBR	NBR
Spacer	Acetal resin	Technopolymer (Alluminium for G1")
Spool	Stainless steel	Stainless steel / Technopolymer
Bottom plates		Technopolymer
Spring	Spring steel	Spring steel

## Use and maintenance

These valves have an average life of 15 million cycles depending on the application and air quality, filtered and lubricated air using specified lubricants will dramatically reduce the wear of the seals and ensures long and trouble free operation.





Please ensure that the valve is being used according with the manufacturers specification, such as air pressure and temperature and that exhaust ports 3 & 5 are protected against the possible ingress of dirt or debris.



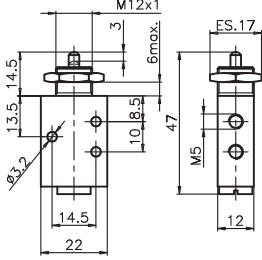
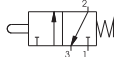

Repair kits including the spool complete with seals are available for overhauling the valves; however, although this is a simple operation it should be carried out by a competent person.

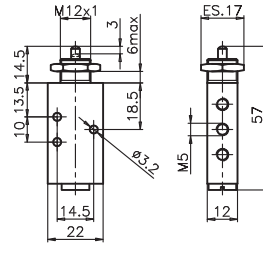

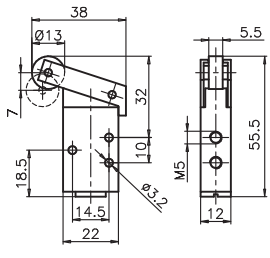
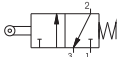

**ATTENTION:** use hydraulic oil class H for lubrication such as MAGNA GC 32 (Castrol).

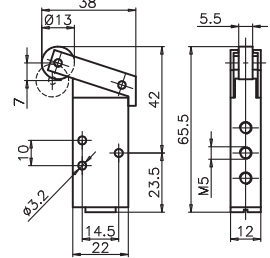

1

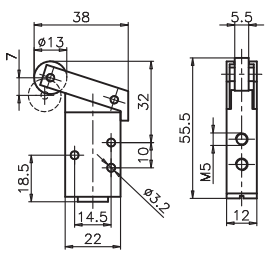
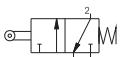
Tappet panel - Spring		3/2	Ordering code	5/2	Tappet panel - Spring											
  <p>Weight gr. 70 Operating force 14 N</p> 		<p><b>105.1.0.1</b></p> <p>TYPE</p> <p>32 = 3 ways</p> <p>52 = 5 ways</p>	  <p>Weight gr. 87 Operating force 14 N</p> 													
					<table border="1"> <thead> <tr> <th rowspan="2">Operational characteristics</th> <th>Fluid</th> <th>Max working pressure</th> <th colspan="2">Operating Temperature</th> <th>Flow rate at 6 bar with <math>\Delta p=1</math></th> <th>Orifice size</th> <th>Working port size</th> </tr> </thead> <tbody> <tr> <td>Filtered and lubricated air</td> <td>10 bar</td> <td>Min. -5°C</td> <td>Max. +70°C</td> <td>120 NI/min</td> <td>mm 2,5</td> <td>M5</td> </tr> </tbody> </table>		Operational characteristics	Fluid	Max working pressure	Operating Temperature		Flow rate at 6 bar with $\Delta p=1$	Orifice size	Working port size	Filtered and lubricated air	10 bar
Operational characteristics	Fluid	Max working pressure	Operating Temperature		Flow rate at 6 bar with $\Delta p=1$	Orifice size		Working port size								
	Filtered and lubricated air	10 bar	Min. -5°C	Max. +70°C	120 NI/min	mm 2,5	M5									

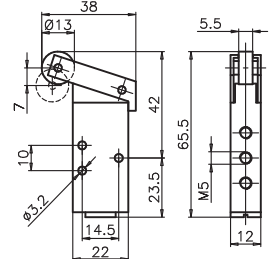
Lever roller - Spring		3/2	Ordering code	5/2	Lever roller - Spring											
  <p>Weight gr. 85 Operating force 6 N</p> 		<p><b>105.1.2.1</b></p> <p>TYPE</p> <p>32 = 3 ways</p> <p>52 = 5 ways</p>	  <p>Weight gr. 102 Operating force 6 N</p> 													
					<table border="1"> <thead> <tr> <th rowspan="2">Operational characteristics</th> <th>Fluid</th> <th>Max working pressure</th> <th colspan="2">Operating Temperature</th> <th>Flow rate at 6 bar with <math>\Delta p=1</math></th> <th>Orifice size</th> <th>Working port size</th> </tr> </thead> <tbody> <tr> <td>Filtered and lubricated air</td> <td>10 bar</td> <td>Min. -5°C</td> <td>Max. +70°C</td> <td>120 NI/min</td> <td>mm 2,5</td> <td>M5</td> </tr> </tbody> </table>		Operational characteristics	Fluid	Max working pressure	Operating Temperature		Flow rate at 6 bar with $\Delta p=1$	Orifice size	Working port size	Filtered and lubricated air	10 bar
Operational characteristics	Fluid	Max working pressure	Operating Temperature		Flow rate at 6 bar with $\Delta p=1$	Orifice size		Working port size								
	Filtered and lubricated air	10 bar	Min. -5°C	Max. +70°C	120 NI/min	mm 2,5	M5									

Lever roller ball bearing - Spring		3/2	Ordering code	5/2	Lever roller ball bearing - Spring											
  <p>Weight gr. 100 Operating force 6 N</p> 		<p><b>105.1.2.1/1</b></p> <p>TYPE</p> <p>32 = 3 ways</p> <p>52 = 5 ways</p>	  <p>Weight gr. 177 Operating force 6 N</p> 													
					<table border="1"> <thead> <tr> <th rowspan="2">Operational characteristics</th> <th>Fluid</th> <th>Max working pressure</th> <th colspan="2">Operating Temperature</th> <th>Flow rate at 6 bar with <math>\Delta p=1</math></th> <th>Orifice size</th> <th>Working port size</th> </tr> </thead> <tbody> <tr> <td>Filtered and lubricated air</td> <td>10 bar</td> <td>Min. -5°C</td> <td>Max. +70°C</td> <td>120 NI/min</td> <td>mm 2,5</td> <td>M5</td> </tr> </tbody> </table>		Operational characteristics	Fluid	Max working pressure	Operating Temperature		Flow rate at 6 bar with $\Delta p=1$	Orifice size	Working port size	Filtered and lubricated air	10 bar
Operational characteristics	Fluid	Max working pressure	Operating Temperature		Flow rate at 6 bar with $\Delta p=1$	Orifice size		Working port size								
	Filtered and lubricated air	10 bar	Min. -5°C	Max. +70°C	120 NI/min	mm 2,5	M5									

1

<b>Lever button - Spring</b>		3/2	<b>Ordering code</b> <b>105.T.2.6/C</b>		5/2	<b>Lever button - Spring</b>								
				<table border="1"> <tr><td>TYPE</td></tr> <tr><td>T 32 = 3 ways</td></tr> <tr><td>52 = 5 ways</td></tr> <tr><td>BUTTON COLOR</td></tr> <tr><td>C 1 = Red</td></tr> <tr><td>2 = Black</td></tr> <tr><td>3 = Green</td></tr> </table>		TYPE	T 32 = 3 ways	52 = 5 ways	BUTTON COLOR	C 1 = Red	2 = Black	3 = Green		
						TYPE								
T 32 = 3 ways														
52 = 5 ways														
BUTTON COLOR														
C 1 = Red														
2 = Black														
3 = Green														
Weight gr. 85 Operating force 6 N						Weight gr. 102 Operating force 6 N								
<b>Operational characteristics</b>	Fluid	Max working pressure	Operating Temperature		Flow rate at 6 bar with $\Delta p=1$	Orifice size	Working port size							
	Filtered and lubricated air	10 bar	Min. -5°C	Max. +70°C	120 NI/min	mm 2,5	M5							

<b>Lever unidirectional - Spring</b>		3/2	<b>Ordering code</b> <b>105.T.3.1</b>		5/2	<b>Lever unidirectional - Spring</b>				
				<table border="1"> <tr><td>TYPE</td></tr> <tr><td>T 32 = 3 ways</td></tr> <tr><td>52 = 5 ways</td></tr> </table>		TYPE	T 32 = 3 ways	52 = 5 ways		
						TYPE				
T 32 = 3 ways										
52 = 5 ways										
Weight gr. 85 Operating force 6 N						Weight gr. 102 Operating force 6 N				
<b>Operational characteristics</b>	Fluid	Max working pressure	Operating Temperature		Flow rate at 6 bar with $\Delta p=1$	Orifice size	Working port size			
	Filtered and lubricated air	10 bar	Min. -5°C	Max. +70°C	120 NI/min	mm 2,5	M5			

<b>Lever panel Ø22 - 2 positions</b>		3/2	<b>Ordering code</b> <b>105.T.4/C</b>		5/2	<b>Lever panel Ø22 - 2 positions</b>								
				<table border="1"> <tr><td>TYPE</td></tr> <tr><td>T 32 = 3 ways</td></tr> <tr><td>52 = 5 ways</td></tr> <tr><td>BUTTON COLOR</td></tr> <tr><td>C 1 = Red</td></tr> <tr><td>2 = Black</td></tr> <tr><td>3 = Green</td></tr> </table>		TYPE	T 32 = 3 ways	52 = 5 ways	BUTTON COLOR	C 1 = Red	2 = Black	3 = Green		
						TYPE								
T 32 = 3 ways														
52 = 5 ways														
BUTTON COLOR														
C 1 = Red														
2 = Black														
3 = Green														
Weight gr. 125						Weight gr. 142								
<b>Operational characteristics</b>	Fluid	Max working pressure	Operating Temperature		Flow rate at 6 bar with $\Delta p=1$	Orifice size	Working port size							
	Filtered and lubricated air	10 bar	Min. -5°C	Max. +70°C	120 NI/min	mm 2,5	M5							



1

<b>Lever panel Ø30 - 2 positions</b>		3/2	<b>Ordering code</b>		5/2	<b>Lever panel Ø30 - 2 positions</b>	
				<b>105.1.5/©</b>			
Weight gr. 165						Weight gr. 182	
<b>Operational characteristics</b>	Fluid	Max working pressure	Operating Temperature		Flow rate at 6 bar with $\Delta p=1$	Orifice size	Working port size
	Filtered and lubricated air	10 bar	Min. -5°C	Max. +70°C	120 NI/min	mm 2,5	M5

<b>Push button Ø30 - Spring</b>		3/2	<b>Ordering code</b>		5/2	<b>Push button Ø30 - Spring</b>	
				<b>105.1.6.1/©</b>			
Weight gr. 123 Operating force 14 N						Weight gr. 140 Operating force 14 N	
<b>Operational characteristics</b>	Fluid	Max working pressure	Operating Temperature		Flow rate at 6 bar with $\Delta p=1$	Orifice size	Working port size
	Filtered and lubricated air	10 bar	Min. -5°C	Max. +70°C	120 NI/min	mm 2,5	M5

<b>Push button Ø22 - Spring</b>		3/2	<b>Ordering code</b>		5/2	<b>Push button Ø22 - Spring</b>	
				<b>105.1.6.2/©</b>			
Weight gr. 102 Operating force 14 N						Weight gr. 119 Operating force 14 N	
<b>Operational characteristics</b>	Fluid	Max working pressure	Operating Temperature		Flow rate at 6 bar with $\Delta p=1$	Orifice size	Working port size
	Filtered and lubricated air	10 bar	Min. -5°C	Max. +70°C	120 NI/min	mm 2,5	M5

1

**Push button - Spring**

3/2

Ordering code

**105.T.6.22/C**

- TYPE  
**T** 32 = 3 ways  
 52 = 5 ways  
 BUTTON COLOR  
**C** 1 = Red  
 2 = Black  
 3 = Green  
 4 = Yellow

5/2

**Push button - Spring**

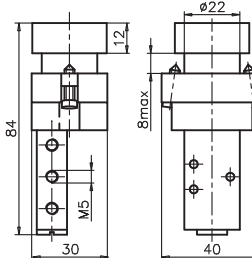
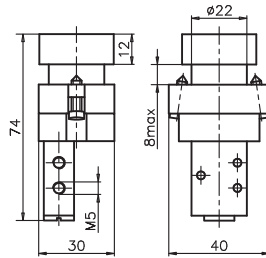

Weight gr. 165  
Operating force 14 N

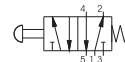
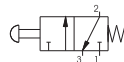

Weight gr. 182  
Operating force 14 N

Operational characteristics	Fluid	Max working pressure	Operating Temperature		Flow rate at 6 bar with $\Delta p=1$	Orifice size	Working port size
	Filtered and lubricated air	10 bar	Min. -5°C	Max. +70°C	120 NI/min	mm 2,5	M5

**Raised Push button - Spring**

3/2

Ordering code

**105.T.6.23/C**

- TYPE  
**T** 32 = 3 ways  
 52 = 5 ways  
 BUTTON COLOR  
**C** 1 = Red  
 2 = Black  
 3 = Green  
 4 = Yellow

5/2

**Raised Push button - Spring**

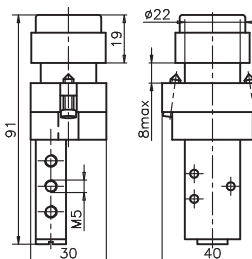
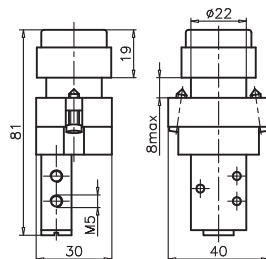

Weight gr. 170  
Operating force 14 N

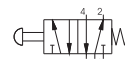
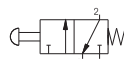

Weight gr. 187  
Operating force 14 N

Operational characteristics	Fluid	Max working pressure	Operating Temperature		Flow rate at 6 bar with $\Delta p=1$	Orifice size	Working port size
	Filtered and lubricated air	10 bar	Min. -5°C	Max. +70°C	120 NI/min	mm 2,5	M5

**Switch 2 positions**

3/2

Ordering code

**105.T.6.27**

- TYPE  
**T** 32 = 3 ways  
 52 = 5 ways

5/2

**Switch 2 positions**

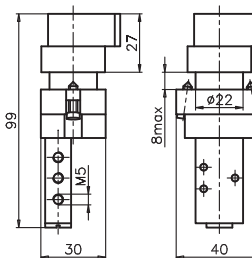
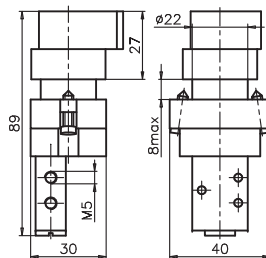

Weight gr. 185

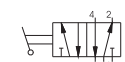
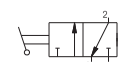







Weight gr. 202

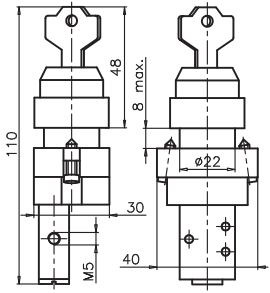

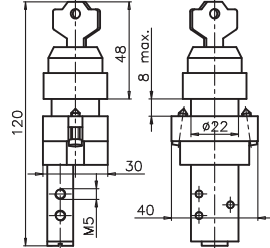
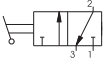
Operational characteristics	Fluid	Max working pressure	Operating Temperature		Flow rate at 6 bar with $\Delta p=1$	Orifice size	Working port size
	Filtered and lubricated air	10 bar	Min. -5°C	Max. +70°C	120 NI/min	mm 2,5	M5

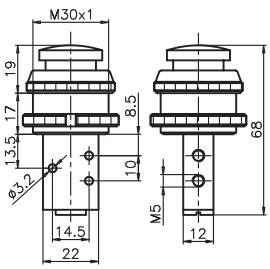

1

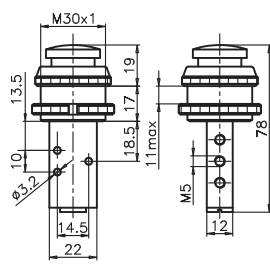
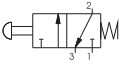
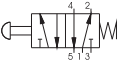
<b>Key switch 2 positions</b>		3/2	Ordering code		5/2	<b>Key switch 2 positions</b>	
 			<b>105.1.6.28</b>			 	
			TYPE T 32 = 3 ways 52 = 5 ways				
Weight gr. 215						Weight gr. 232	
<b>Operational characteristics</b>	Fluid	Max working pressure	Operating Temperature		Flow rate at 6 bar with $\Delta p=1$	Orifice size	Working port size
	Filtered and lubricated air	10 bar	Min. -5°C	Max. +70°C	120 NI/min	mm 2,5	M5

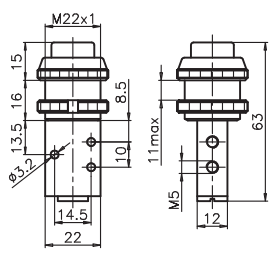
<b>Palm pushbutton Ø30 - Spring</b>		3/2	Ordering code		5/2	<b>Palm pushbutton Ø30 - Spring</b>	
 			<b>105.1.7.1/C</b>			 	
			TYPE T 32 = 3 ways 52 = 5 ways BUTTON COLOR C 1 = Red 2 = Black 3 = Green				
Weight gr. 126 Operating force 14 N						Weight gr. 143 Operating force 14 N	
<b>Operational characteristics</b>	Fluid	Max working pressure	Operating Temperature		Flow rate at 6 bar with $\Delta p=1$	Orifice size	Working port size
	Filtered and lubricated air	10 bar	Min. -5°C	Max. +70°C	120 NI/min	mm 2,5	M5

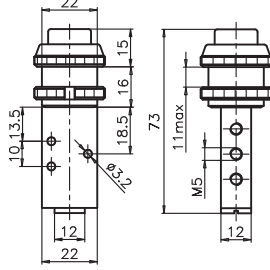
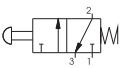
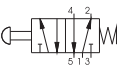
<b>Palm pushbutton Ø22 - Spring</b>		3/2	Ordering code		5/2	<b>Palm pushbutton Ø22 - Spring</b>	
 			<b>105.1.7.2/C</b>			 	
			TYPE T 32 = 3 ways 52 = 5 ways BUTTON COLOR C 1 = Red 2 = Black 3 = Green				
Weight gr. 103 Operating force 14 N						Weight gr. 120 Operating force 14 N	
<b>Operational characteristics</b>	Fluid	Max working pressure	Operating Temperature		Flow rate at 6 bar with $\Delta p=1$	Orifice size	Working port size
	Filtered and lubricated air	10 bar	Min. -5°C	Max. +70°C	120 NI/min	mm 2,5	M5

1

**Push button - Spring**

3/2

**Ordering code**

**105.T.8.1/C**

- T** TYPE  
32 = 3 ways  
52 = 5 ways
- C** BUTTON COLOR  
1 = Red  
2 = Black  
3 = Green

5/2

**Push button - Spring**

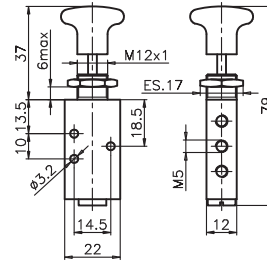
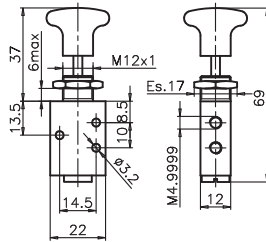

Weight gr. 75  
Operating force 14 N

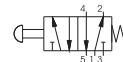
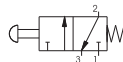

Weight gr. 92  
Operating force 14 N

Operational characteristics	Fluid	Max working pressure	Operating Temperature		Flow rate at 6 bar with $\Delta p=1$	Orifice size	Working port size
	Filtered and lubricated air	10 bar	Min. -5°C	Max. +70°C	120 NI/min	mm 2,5	M5

**Push button 2 positions**

3/2

**Ordering code**

**105.T.8/C**

- T** TYPE  
32 = 3 ways  
52 = 5 ways
- C** BUTTON COLOR  
1 = Red  
2 = Black  
3 = Green

5/2

**Push button 2 positions**

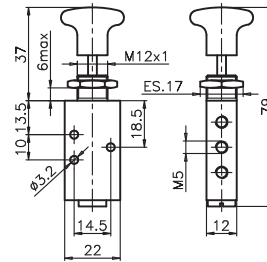
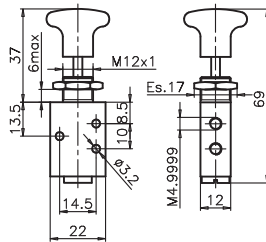

Weight gr. 75  
Operating force 14 N

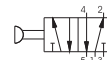
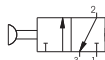

Weight gr. 92  
Operating force 14 N

Operational characteristics	Fluid	Max working pressure	Operating Temperature		Flow rate at 6 bar with $\Delta p=1$	Orifice size	Working port size
	Filtered and lubricated air	10 bar	Min. -5°C	Max. +70°C	120 NI/min	mm 2,5	M5

**Whisker - Spring**

3/2

**Ordering code**

**105.T.9.1**

- T** TYPE  
32 = 3 ways  
52 = 5 ways

5/2

**Whisker - Spring**

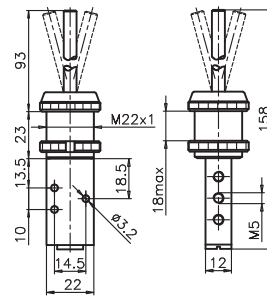
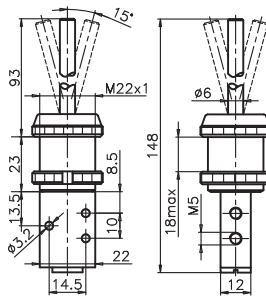

Weight gr. 136

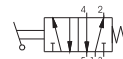
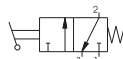

Weight gr. 153

Operational characteristics	Fluid	Max working pressure	Operating Temperature		Flow rate at 6 bar with $\Delta p=1$	Orifice size	Working port size
	Filtered and lubricated air	10 bar	Min. -5°C	Max. +70°C	120 NI/min	mm 2,5	M5



1

Handle with valve

3/2

Ordering code
<b>105.32.6.40</b>
FUNCTION
A = Norm. open N.O.
C = Norm. closed N.C.

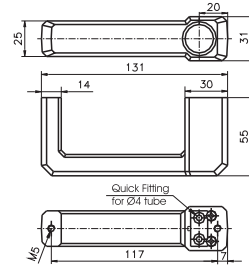

Weight gr. 165  
Operating force 14 N

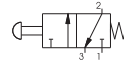
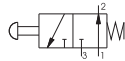

<b>Operational characteristics</b>	Fluid	Max working pressure	Operating Temperature		Flow rate at 6 bar with $\Delta p=1$	Orifice size	Working port size
	Filtered and lubricated air	10 bar	Min. -5°C	Max. +70°C	120 NI/min	mm 2,5	M5 - Quick Fitting for Ø4 tube

Handle with valve

5/2

Ordering code

5/2

Handle with valve

Left feeding

Right feeding

**105.52.6.**

- TYPE
- 40 = Left feeding
  - 40D = Right feeding

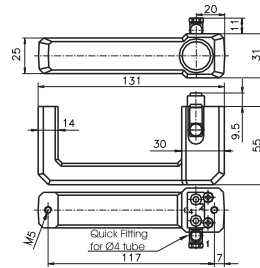
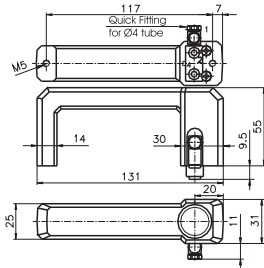

Weight gr. 190  
Operating force 14 N

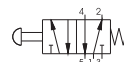

Weight gr. 190  
Operating force 14 N

<b>Operational characteristics</b>	Fluid	Max working pressure	Operating Temperature		Flow rate at 6 bar with $\Delta p=1$	Orifice size	Working port size
	Filtered and lubricated air	10 bar	Min. -5°C	Max. +70°C	120 NI/min	mm 2,5	M5 - Quick Fitting for Ø4 tube